

**SELF OR MANUALLY CLOSING
FLOOD BARRIER
PRODUCT INFORMATION
MODEL: HINGED FLOODGATE**



SELF OR MANUALLY CLOSING FLOOD BARRIER PRODUCT INFORMATION

TABLE OF CONTENTS:

	Page
General Principles of Operation	3
<ul style="list-style-type: none">• System Activation• Typical Deployment Sequence Schedule• Alarms• Flood Barrier Close Times• System Testing	
Product Specification	5
Typical System Layout for Self Closing version	7
Control Panel Diagram	8

GENERAL PRINCIPLES OF OPERATION – SELF CLOSING

- The HINGED FLOODGATE Self Closing Flood Barrier is designed to be activated automatically when floodwaters reach a pre-determined level.
- The concept is based on a single or pair of swing gates with operational auxiliary equipment attached to gates and building structure.

System deployment from open position to closed is achieved via hydraulic rams.

The system has an electronic control system that will activate gates deployment ram motors, as well as audible and visual pending deployment alarms through a switchboard enclosed in a powder coated, locked control panel. Permanent power supply is a design feature. This is provided by the ability of the system to function on a 24 volt battery power pack with no dependence for operation on sites main power. The 24 volt power pack is on permanent charge from site main power and typically remains in deployment standby mode for a minimum 7 days without receiving charge power from sites main power supply. The 24 volt power pack also provides a minimum of 10 deployment functions without receiving a re-charge.

- Note that the flood barrier swing gates can be supplied as a manual operation version.

1. System activation

System deployment controls to be activated by a floodwater collection control pit. This pit contains float switches that will activate deployment power source as well as the gate alarm system at a pre-determined water level. The control pit is typically located in a position to allow collection of flood waters prior to flood water entering the protected area of building. This allows deployment of flood water defense gate based on a pre-determined design time step.

2. Typical Deployment sequence schedule

Deployment signal will initiate the following sequence:

- Early flood warning followed by Barrier Deployment alarms will signal flood gate will shortly be in operation.
- 30 seconds after Red alarms are activated a signal will be sent to the barrier ram motors and the barrier gate will close.
- Once floodwaters recede, the float switch will return to its vertical position and the control panel will send the "open" signal to the rams.
- The barrier rams will pull the gate back to the open position.
- Alarms will cease.

- Alarm system is designed to continue until such time as the barrier gate returns to open position; however a system mute switch is available to building manager (or Flood Response Officer) to reduce the volume of the audible alarm. This does NOT turn off the warning lights.
- The system operates off a permanently charged, fail safe, rechargeable battery power supply, which will guarantee deployment in the event of electrical power failure. This form of power supply is necessary as electricity is frequently lost during large storm events.

3. Alarms

Typically two linked systems are installed:

- Early flood warning (AMBER)

Beacons and signage are located at the barrier and other locations as required.

Amber alarms warn occupants to move to higher ground and that flood barrier is preparing to deploy.

- Flood Barrier deployment imminent (RED)

Strobe light and audible bell are located on control panel.

Flashing beacons are positioned as required.

Red alarm alerts all occupants to the fact that flood barriers are about to close and to stand well clear.

No vehicles should use the driveways after the RED alarms are activated, either to park in the garage or to leave the site, because of the risk of colliding with the closing barrier.

4. Flood Barrier Closure Time

The self-closing flood barrier operates under hydraulic pressure provided by the systems motor power pack and hydraulic rams.

The barrier closure may be regulated based on flood water flow or ponding-rate. Time sequence for barrier to fully deploy after the control panel receives a signal from the flood water control pit is typically 30 seconds maximum.

5. System Testing

Performance of the barrier can be checked at any time. This is achieved by activating the test function in control panel.

The control panel allows site management to also pre-deploy the barrier at any time to provide building protection from pending flood.

PRODUCT SPECIFICATION

For HINGED FLOODGATE

Automatic/Self Closing Flood Barriers

Note: Designed for self-contained operation and not dependent on mains site power

1. **Barrier Support Frame**
 - Heavy duty duragal R.H.S – grade C450LO to AS 1163.
2. **Barrier Gate Section**
 - One steel zincalume sheet, thickness to project design flood height loadings.
3. **Barrier Hinge Bearings**
 - Selected heavy duty roller bearings and high tensile steel shaft.
4. **Operational Hydraulic Rams**
 - Hydraulic cylinders with industrial type pin eyes, 50mm to 100mm DIA bore, stroke length as required. Operational force range (14 PSI to 125PSI – dependent on site-specific requirements).
5. **Hydraulic Power Pack Unit**
 - Bucher hydraulics double acting 24 volt D.C model M – 3551 or Lux-L combined ram/motor unit.
6. **Operational Control Float Level Switches**
 - Matelec 9006 series/cable length max 40m.
7. **Operational Control Panel**
 - Australian made 240 volt / 24 volt D.C panel including 24 volt battery pack for system function and charger with powder coated cabinet.
 - Controls include interface of level sensor float level switches with:
 - Warning alarms, audible and visual
 - Security gates (if required)
 - Remote signal (if required)
 - Adjustable time step to barrier deployment signal
 - System testing function

8. Barrier Water Seals

- Durafoam series 6110 E.P.D.M selected profile and/or E.P.D.M section P type.

9. Barrier Surface Finish

- A & I Coatings vitrethane 630 two pack aliphatic polyurethane min. 50 micron Thickness or two pack epoxy type.

10. Barrier High Visible Markings

- Dulux Weathermax HBR polyurethane L.F line markings. Colour high-viz yellow.

Note: Flooding Solutions Advisory Group reserve the right to amend this product specification from time to time based on further and on-going product development. Flooding Solutions Advisory Group also undertake to promptly advise all committed clients of any proposed modification to design that may effect this product specification.

Control Panel Diagram

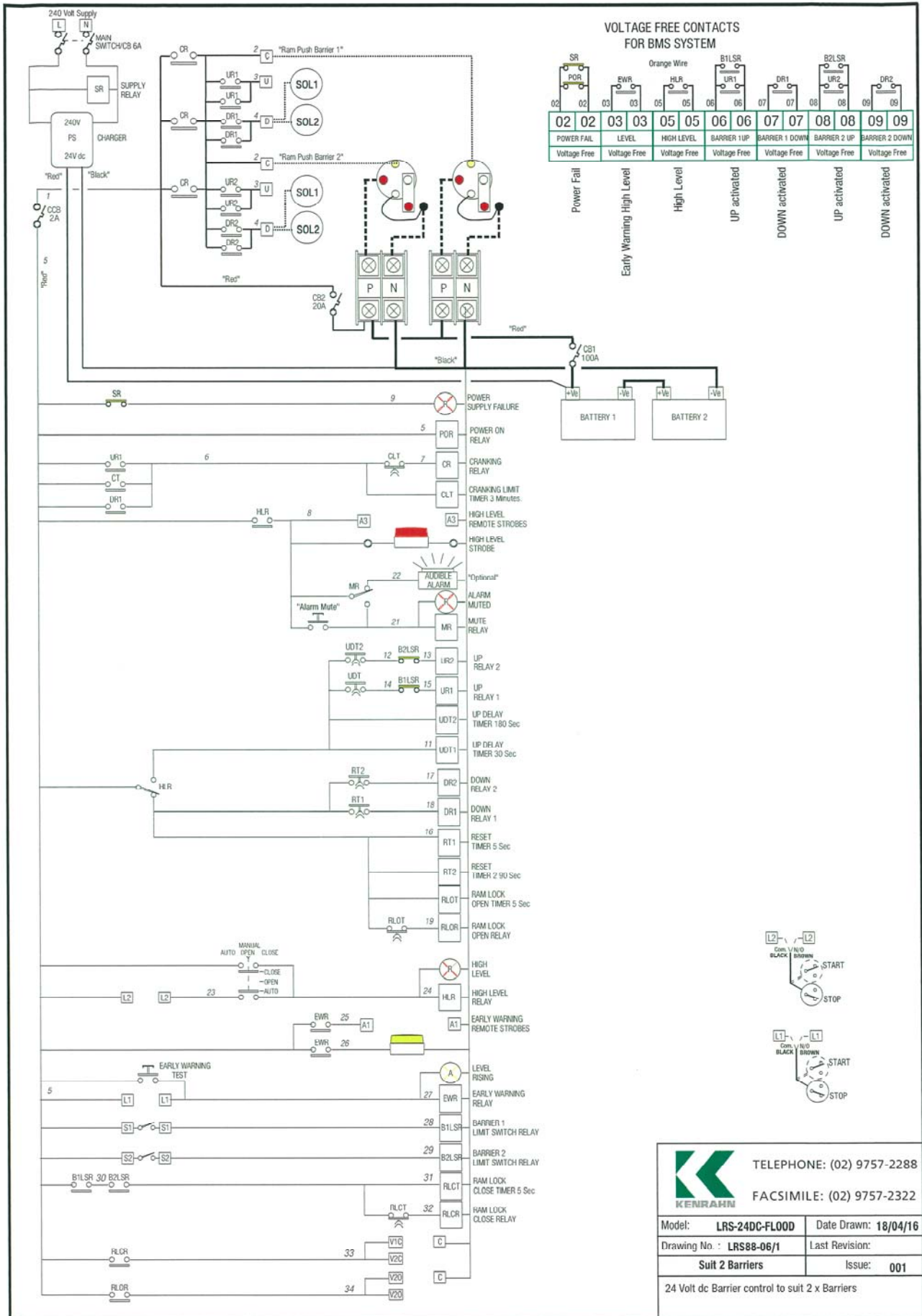

TELEPHONE: (02) 9757-2288
FACSIMILE: (02) 9757-2322

Model: LRS-24DC-FLOOD	Date Drawn: 18/04/16
Drawing No.: LRS88-06/1	Last Revision:
Suit 2 Barriers	Issue: 001

24 Volt dc Barrier control to suit 2 x Barriers

Flooding Solutions

ADVISORY GROUP

CONTACT

EM: info@floodingsolutions.com.au

PH: (+612) 4474 4711

FX: (+612) 4474 4105

14 Page St. Moruya NSW 2537 Australia

floodingsolutions.com.au